

GP Batteries

Product Specifications

Model No.: GPZA312

Document Number: ZA0003

Revision:02

Page 1 of 5

1. APPLICABILITY

This specification is applicable to GP Zinc Air GPZA312.

2. GENERAL

2.1	Type designation	: PR41(IEC/JIS) / 7002ZD(ANSI)
2.2	Nominal voltage	: 1.4V
2.3	Shape and dimension	: Refer to Drawing 1.
2.4	Typical Capacity	: 125mAh (continuous discharge under 1300Ω to 0.9V at 20°C)
2.5	Typical weight	: 0.6g
2.6	Warranty period	: 12 months
2.7	Date code	: Unless otherwise specified, every battery will carry an expiry date code for 36 months. (e.g. a battery manufactured on January 2009 will carry an expiry code of 01-12.)

3. APPEARANCE

There shall be no dirt, scratch or deformation detrimental to practical service in appearance.

4. CELL VOLTAGE

4.1 Test method I

Method of sampling	: MIL-STD-105E level II single sampling normal inspection.
Voltmeter	: Digital Voltmeter (DVM) with the precision of 1mV (internal resistance not less than 1 Megohm)
Test temperature	: 20±2°C

4.2 Off Load Voltage

At shipping	12 months after manufactured
*1.35V to 1.45V	*1.35V to 1.45V

4.3 On Load Voltage

Initial	12 months after manufactured
*Above 1.3V	*Above 1.3V

Load resistance : 1.3kΩ ± 0.5% (measure time : 0.8 seconds)

*Take away the tape on battery and wait for 15 minutes before measure Voltage.

GP Batteries

Product Specifications

Model No.:GPZA312

Document Number: ZA0003

Revision:02

Page 2 of 5

5. SERVICE OUTPUT

5.1 Test method

- (1) The resistance of external discharge circuit shall be as specified plus or minus 0.5%.
- (2) The duration of discharge time periods shall be as specified plus or minus 1%.
- (3) Storage shall be at $20\pm 2^{\circ}\text{C}$, $65\pm 20\%\text{RH}$ and discharge tests shall be at $20\pm 2^{\circ}\text{C}$, $65\pm 20\%\text{RH}$.

5.2 Service Life

	Test Mode	Application	Initial (Nominal)	Initial (Minimum)	12 months storage at 20°C (Nominal)
Service life at $20\pm 2^{\circ}\text{C}$	1.3k Ω continuous (EPV=0.9V)	Reference test	110H	90H	88H

M: minute H: hour EPV: end point voltage

*The initial discharge test shall commence within 30 days of manufacture. During this period, the cells shall be stored under room temperature conditions. ($20\pm 2^{\circ}\text{C}$ and $65\pm 20\%$ relative humidity)

**Take away the tape on battery and wait for 15 minutes before measure Service Life.

6. ELECTROLYTE LEAKAGE

6.1 Leakage on arrival at warehouse.

Leakage shall be checked with naked eye. No leakage shall be observed with the naked eye; and no bulging exceeding the maximum dimensions shall result.

6.2 Leakage at room temperature

After storing for 12 months at $20\pm 15^{\circ}\text{C}$, $65\pm 20\%\text{RH}$, no leakage shall be observed with the naked eye; and no bulging exceeding the maximum dimensions shall result.

6.3 Leakage at high temperature

Within thirty days of manufacture, the cell shall be stored for 30 days at $45\pm 2^{\circ}\text{C}$ and below 70% relative humidity, no leakage shall be observed with the naked eye; and no bulging exceeding the maximum dimensions shall result.

6.4 Leakage of over discharge

After loading with 1.3k Ω continuously down to 0.8V at $20\pm 2^{\circ}\text{C}$, $65\pm 20\%\text{RH}$, no leakage shall be observed with the naked eye; and no bulging exceeding the maximum dimensions shall result.

GP Batteries

Product Specifications

Model No.:GPZA312

Document Number: ZA0003

Revision:02

Page 3 of 5

7. QUALITY ASSURANCE

DESCRIPTION	SAMPLING PLAN
Battery dimensions	0.65% (Note 5)
Appearance	1.0% (Note 5)
Off load voltage	0.65% (Note 5)
On load voltage	1.0% (Note 5)
Service output	Note 1 (Note 5)
Leakage 6.1	0.65% (Note 2 & 5)
6.2	Note 3
6.3	Note 4
6.4	Note 4

Note 1 : Acceptance / rejection in accordance with IEC publication 60086-1 (2007), Sub-clause 5.3

- 1) Test nine batteries.
- 2) Calculate the average without the exclusion of any result.
- 3) If this average is equal to or greater than the specified figure and no more than one battery has a service output of less than 80% of the specified figure, the batteries are considered to conform for service output.
- 4) If this average is less than the specified figure and/or more than one battery has a service output of less than 80% of the specified figure, repeat the test on another sample of nine batteries and calculate the average as previously.
- 5) If the average of this second test is equal to or greater than the specified figure and no more than one battery has a service output of less than 80% of the specified figure, the batteries are considered to conform for service output.
- 6) If the average of second test is less than the specified figure and/or more than one battery has a service output of less than 80% of the specified figure, the batteries are considered not to conform and no further testing is permitted.

Note 2: Leakage on arrival at warehouse is within two months after shipping.

Note 3: Sample size : n=20
Judgement : Ac=1 Re=2

Note 4: Sample size :n=20
Judgement :Ac=0, Re=1

Note 5: AQL General Inspection level II, single sampling plan.

8. PACKAGING

Packaging shall be a form agreed by both parties.

GP Batteries

Product Specifications

Model No.:GPZA312

Document Number: ZA0003

Revision:02

Page 4 of 5

Precaution & Handling

- 1) Do not disassemble or short-circuit batteries.
- 2) Do not recharge batteries.
- 3) Do not dispose of batteries in fire.
- 4) Do not allow metal objects to contact the battery terminals.
- 5) Do not mix with used or other battery type (such as alkaline with carbon zinc).
- 6) Do not solder the batteries directly. If soldering or welding connection to the battery is required, consult our engineer for proper methods.
- 7) Do not over-discharge batteries. Force discharging batteries by external power source in a series may cause explosion.
- 8) To install or remove batteries, follow the equipment manufacturer's instructions.
- 9) Keep battery away from small children. If swallowed, consult a physician at once.
- 10) Remove batteries from device when it is not in use.

Storage

- 1) Store in a cool, dry place before use.
- 2) Do not keep batteries at temperature of 30°C or above.
- 3) Do not keep batteries at relative humidity of 75% or above.

GP Batteries

Product Specifications

Model No.: GPZA312

Document Number: ZA0003

Revision:02

Page 5 of 5

Drawing 1

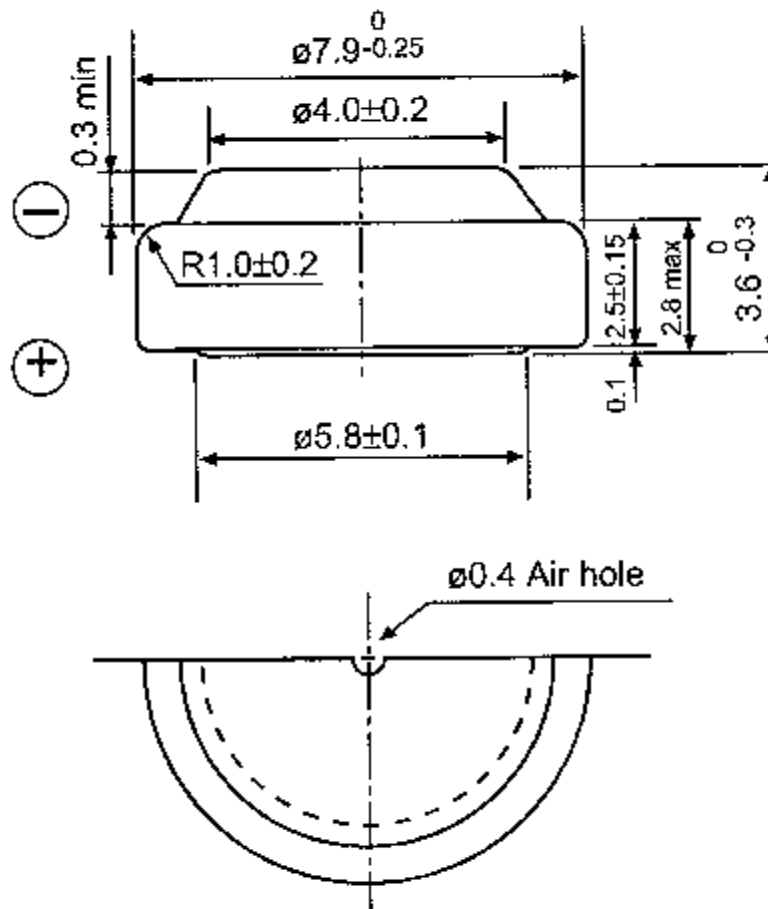

Unit : mm